



Maintenance
& Installation

www.janper.com.au

JANPER[®]
Quality Cabinetry Products

Janper's Care and Maintenance Instructions

(To get the best life and usage of Duraform[®] Doors)

Note: Failure to follow any of the instructions void the warranty

Cleaning

- Spills and marks should be cleaned off immediately and not left on the door for an indefinite period.
- To clean doors, use warm soapy water and a soft cloth to wipe dry, for stubborn stains a soft brush may be necessary to soften and remove.
- **The following MUST NOT be used: abrasive cleaners, scouring pads or abrasive papers, solvents, thinners, turps, ammonia, bleach, acetone and other cleaning agents containing organic solvents and/or the above mentioned products.**
- For really stubborn stains e.g. Ballpoint pen marks, a cotton bud soaked in non aggressive solvent (diluted methylated spirits) can be used just on the stain area but must be washed away immediately and dried so that no solvent is remaining on the door.

Protective Coating

The protective coating supplied on full gloss and matt wrapped doors should not be removed until the installation is complete.

Storing of Doors

When doors are stored at the cabinet maker's workshop, they should be kept inside and away from direct sunlight. Care should be taken to avoid leaning large doors against the wall with other doors on top, so as not to cause additional bowing.

Doors should be stacked face up.

Care should be taken not to slide doors when boring hinge holes and avoid all contact with sharp objects.

Kitchen Designs

Kitchens should be designed so that doors are not exposed to steam, direct heat or prolonged humidity. Care should be taken to make sure Duraform[®] doors and panels are not positioned close to appliances that give off steam, (e.g. kettles) and heat (e.g. gas hotplates).

(A) Flush mounted and Under Bench Ovens or Ovens with Front Panel Exhausts.

Many ovens on the market do not have a fitted “baffle” surrounding the oven door, and excessive heat is convected to the surrounding cabinetry and doors/panels.

Duraform® doors are manufactured to meet current heat resistance (Uni9242) which requires the door to withstand a temperature of 70° Centigrade for 4 hours.

Where ovens convect heat greater than this, it can shrink the foil wrapped on the edge of the door and cause it to delaminate.

Heat deflector strips are provided by door manufacturers to be installed for ovens, for failure to install these deflector strips when required will void the warranty.

(B) Cooktops and Rangehoods.

Doors and end panels should not be installed in close proximity (less than 650mm) to a cooktop.

When doors and panels are installed around a cooktop in accordance with the above, a 900mm **ducted** rangehood exhaust should be installed (recirculating rangehoods are not recommended).

Hotplates should not be used without the rangehood exhaust fan being switched on.

Retractable rangehoods must also be turned on and the panel pulled out to the full extension, otherwise they convect heat through the sides directly onto doors/panels.

Appliances such as electric frypans and portable electric grills should only be used under an activated rangehood exhaust fan. Similarly toasters used in proximity can have the heat build up reduced by activating the exhaust fan. A cool down period is recommended after long use to prevent any heat build up close to doors/panels.

Failure to use the rangehood or follow any of the above guidelines will void the warranty on the doors and panels.

(C) Use of Melamine Materials for Panels.

Please note that when matching different materials such as melamine board, with laminated foils, variations may occur in colour, finish and UV stability.

NOTE: Please Read Carefully.

Matches to melamine board are a guide only, customers must check that they are acceptable to their standards. Finishes on melamine can vary from board supplier-s and colour matches maybe discontinued at anytime by manufacture of board without notice.

JANPER® will not be responsible for melamine board matches.

Customer: John Citizen CABINETS
 Address: 19 Newcastle Road
Brayswater
 Contact: John
 Phone: (03) 9720 0533
 Fax: (03) 9720 0805

Page No.: 1 of
 Customer Order No.: JD01
 Date Ordered: 1-1-07
 Date Required: Allow 10 working days!

Alterations and cancellations must be made within 4 hours of the order being placed. Any alterations and cancellations after this time could incur a charge. All alterations must be in writing quoting the order number.

Door Type: Murray

Arched: Square:
 Put a cross in circle

Door Colour: New Antique

Texture: Satin: Gloss:

Edge Detail:

Edge mould as per brochure unless otherwise stated

6mm Pencil Round

Ogee

Stepped Pencil Round

2mm Pencil Round

Line No.	Qty.	Height (mm)	Width (mm)	'X' For Square Edge				Description (e.g Door, Panel, Drawers)	Customer Use
				T	B	L	R		
01	2	717	398					Doors	
02	2	717	318				✓		
03	2	717	398					Single Pane Frame	
04	2	717	398					Four Pane Frame	
05	1	650	320	✓	✓		✓	Panel as Door	
06	1	1370	100	✓	✓	✓	✓	Filler	
07									
08	1	650	800		✓	✓	✓	Appliance Frame	
09			Min -	40	-	40	40		
10	*Note: Tick is required for no edge detail on plain panels								
11									
12	1	720	320	✓	✓	✓	✓	Panel - No Face Rout	
13	1	900	600					Panel - No Face Rout	
14	1	2400	300	✓	✓	✓	✓	Kicker Blank	
15									
16	1	2400	600	✓	✓	✓	✓	Double Sided* *Only Available as Panel	
17									
18	1	900	600	✓	✓	✓	✓	100mm Return*	
19									
20	1	4000	1400					Loose Foil	
21									
22	1	400	600					M.W. Frame	
23			Min -	40	40	40	40		

Customer: John Citizen CABINETS
 Address: 19 Newcastle Road
Brayswater
 Contact: John
 Phone: (03) 9720 0533
 Fax: (03) 9720 0805

Page No.: ___ of ___

Customer Order No.: JD01
 Date Ordered: 1-1-07
 Date Required: Allow 10 working days!

Door Type: Murray **Arched:** **Square:** **Door Colour:** New Antique
 Put a cross in circle **Texture:** **Satin:** **Gloss:**

Edge Detail: Put a cross in circle
 Edge mould as per brochure unless otherwise stated 6mm Pencil Round Ogee Stepped Pencil Round 2mm Pencil Round

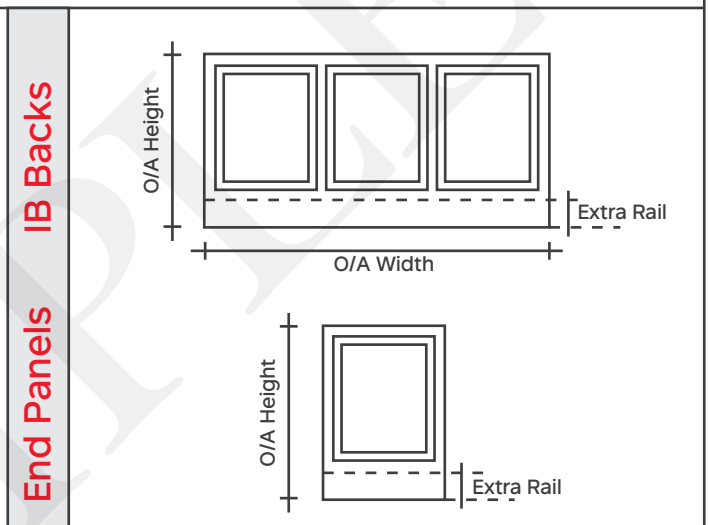
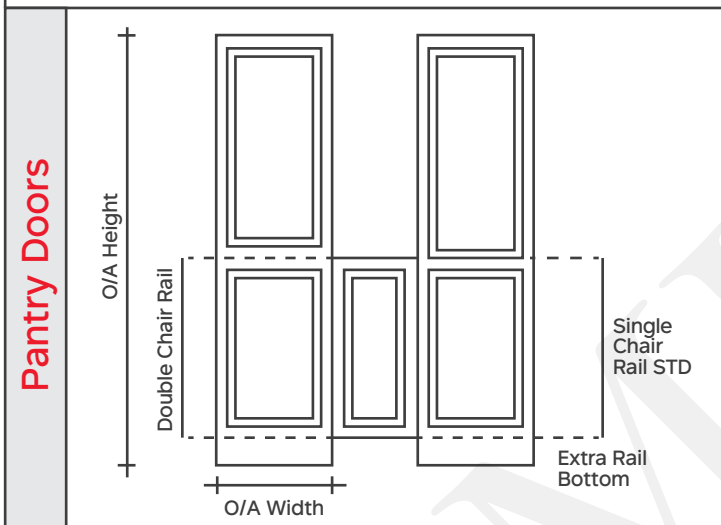

Qty	O/A Height	O/A Width	No Shields	Extra Rail Bottom	Extra Rail Top	'X' Square Edge			
						T	B	L	R
1	2400	600	720	Single	145				
1	2255	600	720	Single	-				
Note: No Extra Rail									
Note: With Extra Rail									

Qty	O/A Height	O/A Width	No Shields	Extra Rail Bottom	Extra Rail Top	'X' Square Edge			
						T	B	L	R
1	3	865	2250	145	-	✓	✓	✓	
1	1	865	580	145	-	✓	✓		
1	1	717	580	-	-				

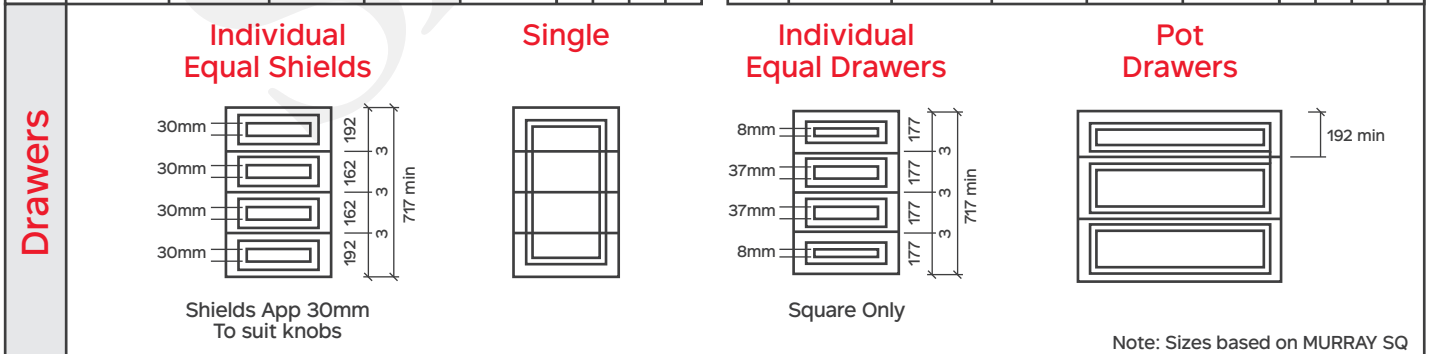

Qty	Drawer Type	Height	Width	'X' Square Edge				Drawer Size			
				T	B	L	R	1	2	3	4
1	Single	717	447					177	177	177	177
1	Indv-Equal Drawers	717	447					177	177	177	177
1	Indv-Equal Shields	717	477					192	162	162	192
1	Indv-Equal Drawers	717	897					192	260	260	

Accessories

Heat Deflectors

Heat Deflectors must be fitted around most modern ovens. Due to their design, heat is not deflected away from doors and surrounding areas. Janper® recommends using heat deflectors along such ovens and failing to do so will make the warranty of the doors null and void.

Strips are available in three sizes:

2400mm, 900mm and 600mm lengths.

Available in a range of colours:

Black, Stainless Steel and White to match today's modern ovens.

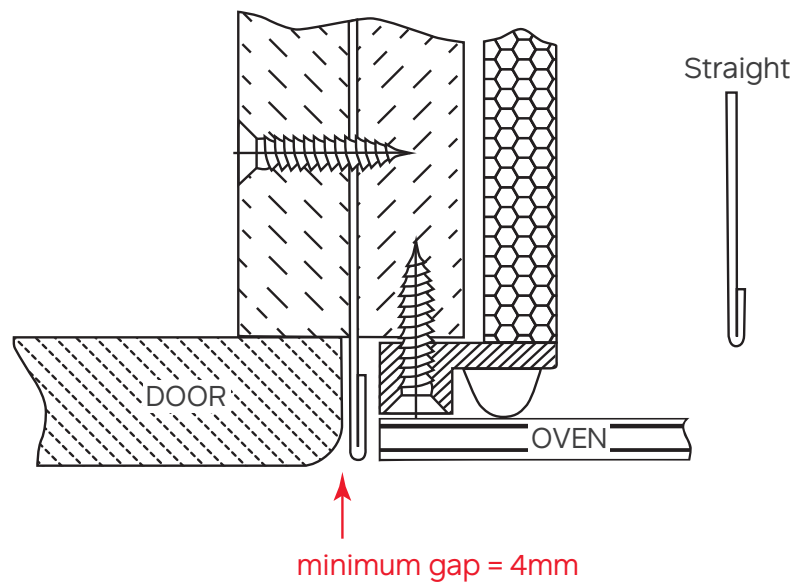
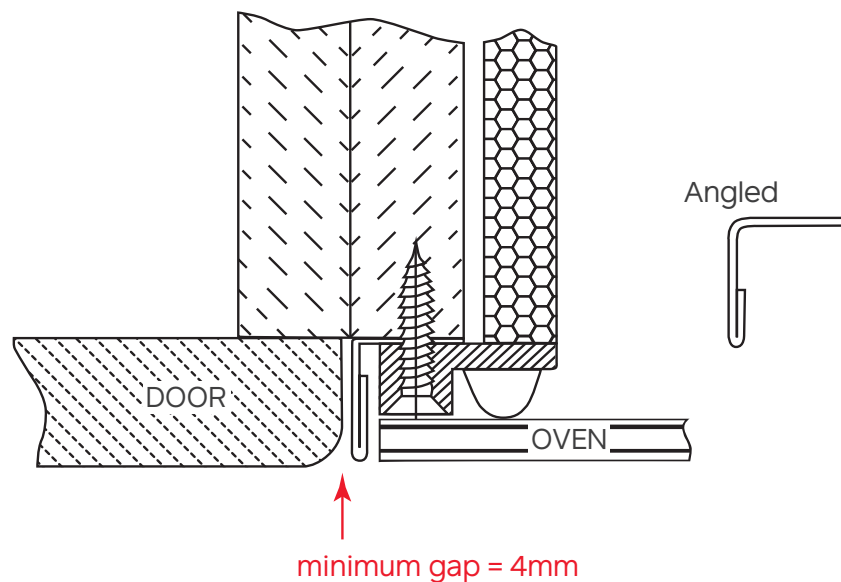

Frequently Asked Questions

- **Does it fade?**

Duraform[®] retains its colour and has undergone extensive quality tests to cope with Australian conditions. (An Australian product for Australian conditions).

- **Does it peel off?**

Duraform[®] is vacuum pressed onto quality MDF board that has been pre-sprayed with heat activated glue especially formulated for this purpose.

- **Can I repaint it?**

We do not recommend painting over the vinyl.

- **Is it more expensive?**

Duraform[®] is competitively priced, less expensive than quality painted surfaces, and approximately the same price as low pressure laminate.

- **How do I clean it?**

Treat Duraform[®] as you would any other vinyl surface, wipe over with a standard soap and water (do not use solvents)

- **Do the edges lift?**

Because Duraform[®] wraps to most curved and routed surfaces there are no edges to lift.

- **Does it scratch or crack?**

Duraform[®] does not crack and is very resistant to impact and general wear and tear.

- **Can Duraform be used near ovens and hotplates?**

Providing standard industry installation codes are observed.

JANPER[®]

Quality Kitchen Products

www.janper.com.au

Janper Pty Ltd

ABN 45 004 772 034

19 Newcastle Rd Bayswater
Victoria 3153

P: (03) 9720 0533

F: (03) 9720 0805

sales@janper.com.au

Distributed by: